

ALUMINIUM HYDRONIC RADIATORS

MANUFACTURED BY:

ragall



★ ★ ★
EN 442

A radiator with a clean and basic style that keeps the harmony profile and expresses itself with great power.

Smooth clean lines and slim profile makes this range perfect for both new homes and replacement radiators. The Aluminium range has a very high thermal efficiency. Manufactured to an award winning standard and with 100% recyclable materials.



10 YEAR*
WARRANTY



FINISHES

High gloss white

COLOUR

Standard white - RAL 9016

MEASUREMENTS

Heights from 570mm to 770mm
Widths from 3 to 25 sections (240mm to 2000mm)

MELBOURNE

Head Office & Showroom
11 Fiveways Blvd
Keysborough VIC 3173
P: 1300 001 800

SYDNEY

Showroom & Warehouse
Unit G7, Alexandria Industrial Estate
35-39 Bourke Road, Alexandria NSW 2015
P: 02 7209 6235



enquiries@huntheat.com.au



huntheat.com.au

Tables based on ΔT 60° C - mean water temperature in radiator of 80°C and room temperature of 20°C.
Radiator outputs to EN442 Standard. - NB: High sizes available for order (not ex stock).

	Height (mm) B	Depth (mm)	Width (mm)	Pipe Centres (D)	Weight (kg)	kW Output
SIRIUS 570	570	97	80	500	1.40	0.123
SIRIUS 670	670	97	80	600	1.64	0.138
SIRIUS 770	770	97	80	700	1.94	0.158

* Data shown per section

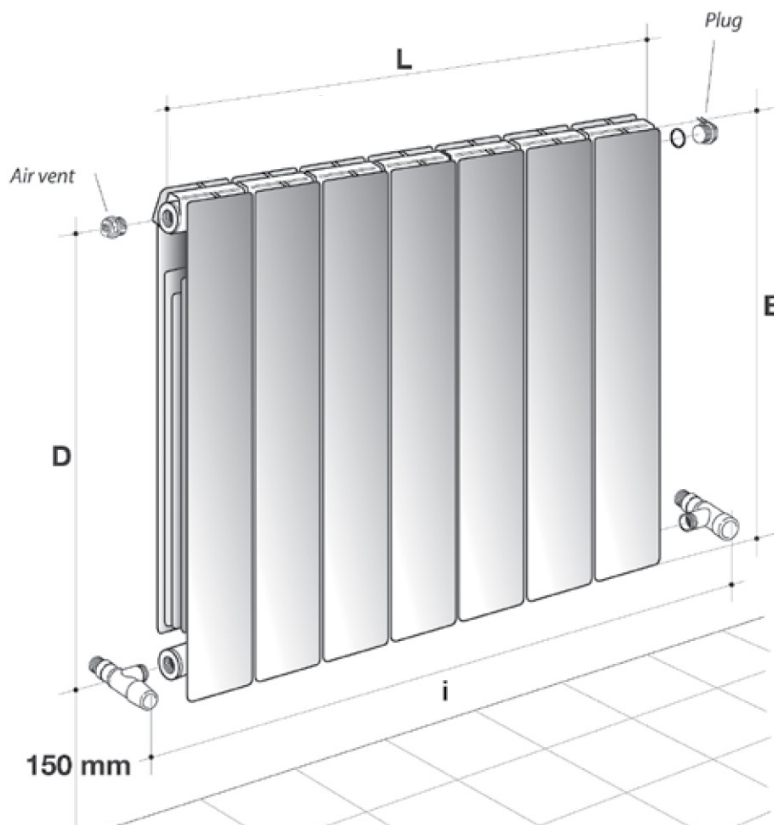

DESIGNED IN ITALY

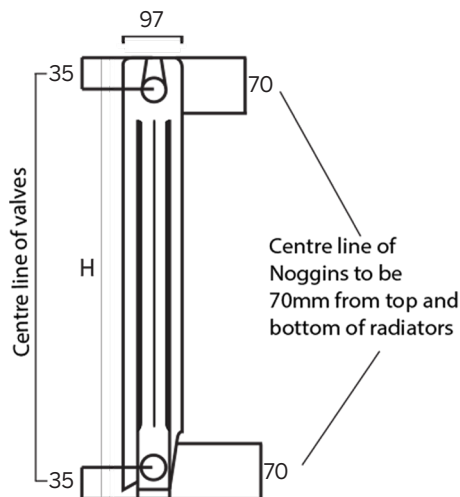

Mark Brackets

Suggested size of noggins, 90 x 40 installed horizontally to either side of the radiator with centre lines 70mm from top/ bottom of the radiator.

This will ensure you have suitable fixings for brackets. You will have been supplied with at least two brackets. The brackets are typically positioned one section in from either end with extra brackets spaced at equal distances between these two.

The two piece brackets can be adjusted both vertically, using the large dome head screw and front and back using the two positions in which the bracket hook can be placed.

