

ART-U FAN COIL

MANUFACTURED BY:



ART-U is the perfect combination of performance and design. With its enviable technical performance, ART-U is able to meet the increasing demands for energy efficiency while also reflecting the latest trends in interior design. The experience of GALLETTI, which has specialised in the development and production of hydronic units for over 60 years, has produced ART-U, a design-driven fan coil suitable for both the residential and commercial heating and cooling sectors.



**10 YEAR*
WARRANTY**

IMMERGAS MAGIS M HEAT PUMP



ART-U COLOUR OPTIONS



COLOURS & FINISHES

Grey
Brushed aluminium front with black side panels

Red (RAL3020)
Red front with black side panels

White (RAL9010)
White front with white side panels

Black
Black front with black side panels

FEATURES & BENEFITS

- Unit with an innovative design and depth down to only 10 cm
- Inverter-controlled BLDC motor
- Low energy consumption
- Modulating operation

Supplied as standard with fitted 240v 3 way valve kit including an insulation shell and pre-installed TED10 controller for individual room temperature control and fan speed adjustment

MELBOURNE

Head Office & Showroom
11 Fiveways Blvd
Keysborough VIC 3173
P: 1300 001 800

SYDNEY

Showroom & Warehouse
Unit G7, Alexandria Industrial Estate
35-39 Bourke Road, Alexandria NSW 2015
P: 02 7209 6235



enquiries@huntheat.com.au



huntheat.com.au



			10			20			30			40			50		
Fan speed			MIN	MED	MAX	MIN	MED	MAX	MIN	MED	MAX	MIN	MED	MAX	MIN	MED	MAX
Control voltage		V	4.50	5.70	6.40	4.90	7.00	10.0	5.40	7.00	10.0	5.50	7.00	10.0	5.50	7.00	10.0
Total cooling capacity	(1)	kW	0.39	0.69	0.80	0.93	1.31	1.66	1.43	2.00	2.42	1.95	2.60	3.13	2.28	3.14	3.69
Sensible cooling capacity	(1)	kW	0.29	0.49	0.62	0.68	0.98	1.26	1.04	1.43	1.82	1.42	1.95	2.39	1.65	2.24	2.79
Water flow	(1)	U/h	67	116	134	161	227	282	247	329	395	338	441	528	395	517	622
Water pressure drop	(1)	kPa	3	1	2	4	8	11	12	20	27	9	15	20	14	23	31
Heating capacity	(2)	kW	0.56	0.73	0.87	1.04	1.38	1.81	1.52	2.09	2.48	1.96	2.66	3.34	2.49	3.07	3.74
Water flow	(2)	U/h	98	126	146	169	238	303	261	413	413	360	457	557	416	528	644
Water pressure drop	(2)	kPa	3	1	2	4	7	12	11	20	27	8	14	20	14	20	28
Rated air flow		m ³ /h	110	141	179	190	275	391	295	390	528	412	529	715	474	609	824
Maximum power input		W	4	5	6	7	11	17	10	14	23	14	20	32	16	23	36
Total sound power level		dB(A)	37	44	49	39	47	54	41	47	54	42	47	54	42	47	54

(1) Water temperature 7 / 12°C, air temperature 27°C dry bulb, 19°C wet bulb (EN 1397:2015)
 (2) Water temperature 45 / 40°C, air temperature 20°C
 Power supply 230-1-50 (V-ph-Hz)

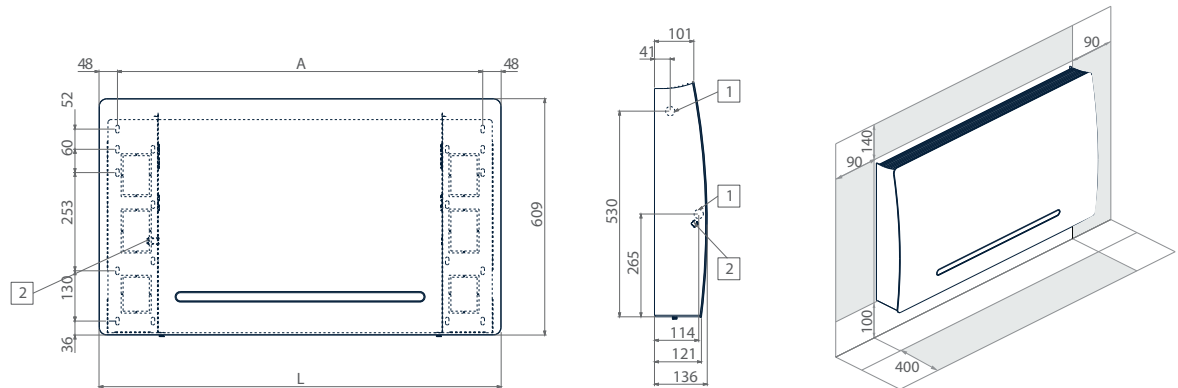

Model	A (mm)	L (mm)	Weight (kg)
ART-U 10	616	711	12
ART-U 20	772	867	14
ART-U 30	914	1036	17
ART-U 40	1173	1268	19
ART-U 50	1307	1402	21

LEGEND	
1	Water connections standard heat exchanger Ø1/2"
2	Condensate discharge diameter for vertical installation Ø17mm

Preinstalled Concealed Control Panel

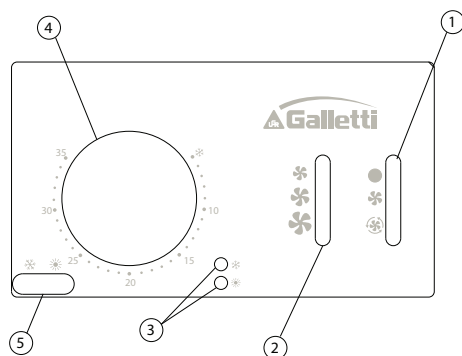

- Three step switch:
 - OFF mode
 - * ON mode with manual ventilation
 - ☼ ON mode with automatic ventilation
- Manual ventilation switch (minimum, middle, maximum speed); this switch has no effects if the main ON/OFF switch is set in the ON mode with automatic ventilation
- Blue and red warning led
 - Led is permanently blue: fan coil is in cooling mode
 - Led is permanently red: fan coil is in heating mode
 - Red led is blinking: water temperature is too low to heat
 - Both red and blue led blinking: temperature probe is faulty or disconnected
- Control knob for temperature setting from 5 to 35°C
- Manual switch mode
 - * SUMMER/COOLING
 - * WINTER/HEATING

PLEASE NOTE: 10 year warranty on heat exchanger, 12 months on all other components.
 * Please contact Hunt Heating for terms & conditions.